

**TECHNICAL DATA**

LOAD.....	10t
SPAN.....	4.2m
LIFTING HEIGHT.....	12m
HOISTING SPEED.....	5/0.8 m/min 2-SPEED
TRAVERSING SPEED.....	0-20 m/min STEPLESS
TRAVELLING SPEED.....	0-20 m/min STEPLESS
WEIGHT OF TROLLEY.....	0.74t
WEIGHT OF CRANE.....	2.3t
POWER SUPPLY.....	380V/48V/50Hz
CRANE GROUP.....	FEM A5
HOIST GROUP.....	MSIFEM 2m
BRIDGE TRAVEL GROUP.....	MSIFEM 2m
SUPPLY POWER.....	11.4kW
TOLERANCES ACC. TO ISO/FEM STANDARD	
BRIDGE PAINT:	E120/RAL1028
DRAWING NOT IN SCALE	

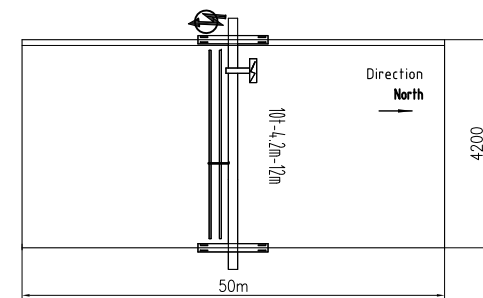
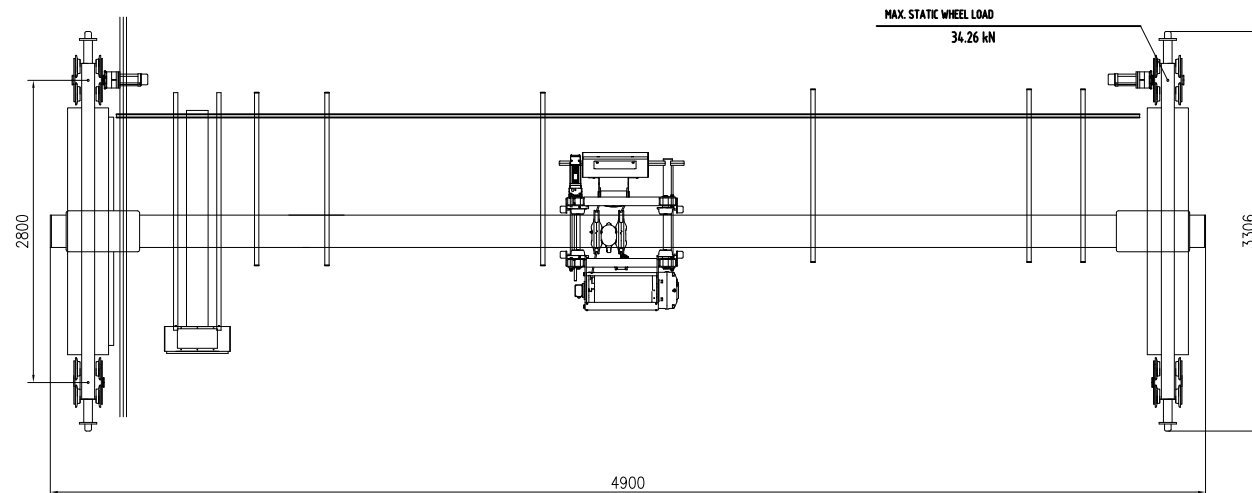

PRELIMINARY DRAWING, OFFER ONLY.

						Material	RU02	
						Material code	Part Name	
Rev.	Pcs.	Area	Mod.Index	Modified	Date	Stage	Weight(Kg)	Issue
Designed	RU02	2023/08/22	Standardized					
Checked			Approved		2023/08/22			
Verified		2023/08/22			Size		2300	A0
Processed			Scale	1:35	A2	Total	Page	DWG No.

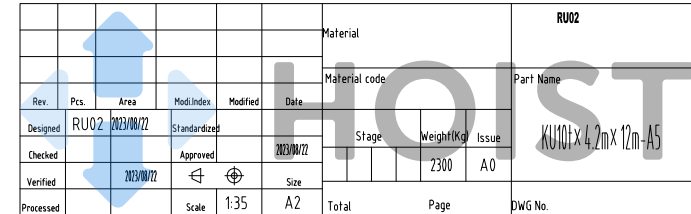

KU101x4.2m x 12m - A5