

TECHNICAL DATA

LOAD.....	20t
SPAN.....	12m
LIFTING HEIGHT.....	12m
HOISTING SPEED.....	4/0.7 m/min 2-SPEED
TRAVERSING SPEED.....	0-20 m/min STEPLESS
TRAVELLING SPEED.....	0-32 m/min STEPLESS
WEIGHT OF TROLLEY.....	1.6t
WEIGHT OF CRANE.....	5.9t
POWER SUPPLY.....	380V/48V/50Hz
CRANE GROUP.....	FEM A5
HOIST GROUP.....	M4(FEM 1Am)
BRIDGE TRAVEL GROUP.....	M5(FEM 2m)
SUPPLY POWER.....	19.8kW
TOLERANCES ACC. TO ISO/FEM STANDARD	
BRIDGE PAINT:.....	E120/RAL1028
DRAWING NOT IN SCALE	

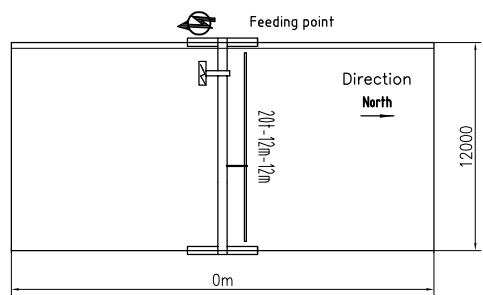

PRELIMINARY DRAWING OFFER ONLY.

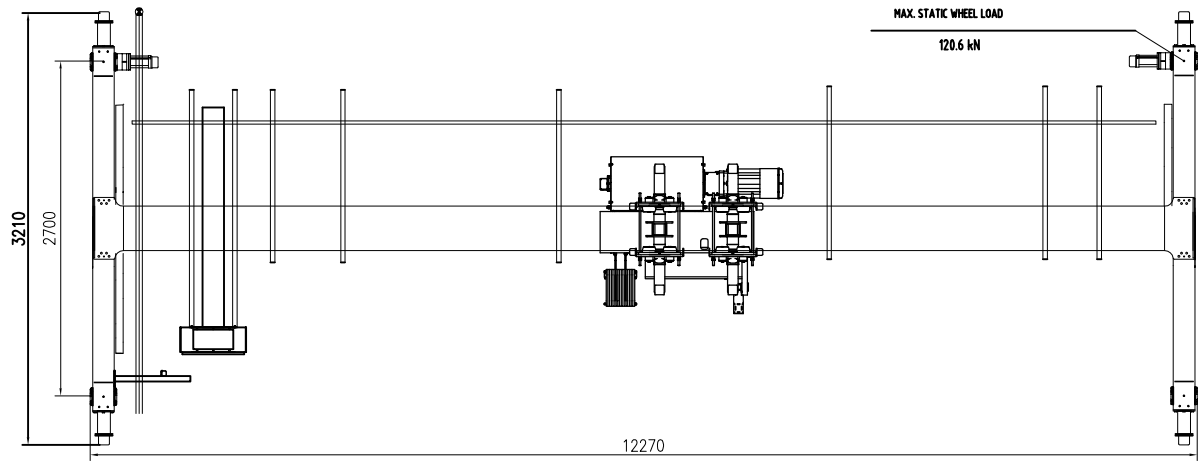

						Name		RU02	
						Material code		Part Name	
Rev.	Pcs.	Area	Mod.Index	Modified	Date	Stage	Weight(Kg)	Issue	KS20tX12mX12m-A5
Designed	RU02	2024/03/21	Standardized		2024/03/21				
Checked			Approved		2024/03/21		5900	A0	
Verified		2024/03/21				Size			
Processed			Scale	1:35	A2	Total	Page	DWG No.	