

TECHNICAL DATA

LOAD.....	5t
SPAN.....	12m
LIFTING HEIGHT.....	6m
HOISTING SPEED.....	5/0.8 m/min 2-SPEED
TRAVERSING SPEED.....	0-20 m/min STEPLESS
TRAVELLING SPEED.....	0-32 m/min STEPLESS
WEIGHT OF TROLLEY.....	0.35t
WEIGHT OF CRANE.....	2.5t
POWER SUPPLY.....	380V/48V/50Hz
CRANE GROUP.....	FEM A5
HOIST GROUP.....	MS(FEM 2m)
BRIDGE TRAVEL GROUP.....	MS(FEM 2m)
SUPPLY POWER.....	6.25kW
TOLERANCES ACC. TO ISO/FEM STANDARD	
BRIDGE PAINT:	E120/RAL1028
DRAWING NOT IN SCALE	

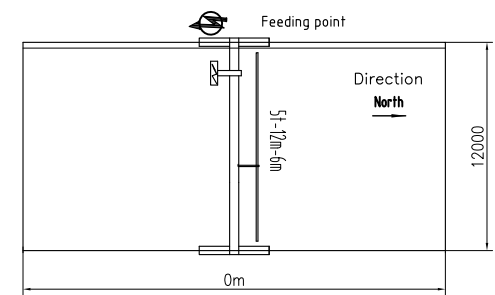

PRELIMINARY DRAWING OFFER ONLY.

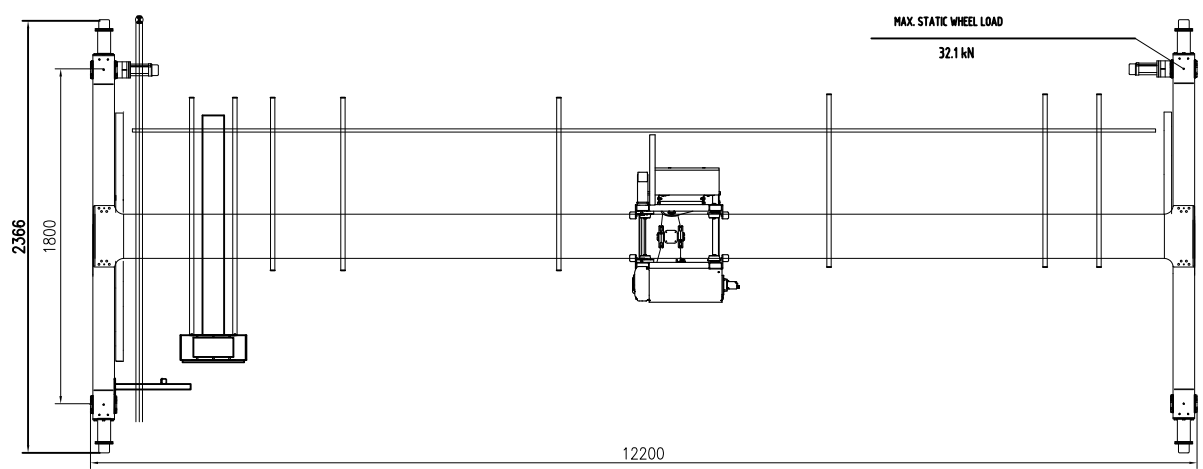

						Name			RU02		
						Material code			Part Name		
Rev.	Pcs.	Area	Mod.Index	Modified	Date						
Designed	RU02	2023/08/21	Standardized			Stage	Weight (Kg)	Issue	KSSJ x 12m x 6m - A5		
Checked			Approved		2023/08/21		2500	A0			
Verified		2023/08/21				Size					
Processed			Scale	1:35	A2	Total	Page	DWG No.			