

TECHNICAL DATA

LOAD.....	2t
SPAN.....	9m
LIFTING HEIGHT.....	9.5m
HOSTING SPEED.....	5.0/8 m/min 2-SPEED
TRAVERSING SPEED.....	0-20 m/min STEPLESS
TRAVELING SPEED.....	0-20 m/min STEPLESS
WEIGHT OF TROLLEY.....	0.26t
WEIGHT OF CRANE.....	15t
POWER SUPPLY.....	380V/48V/50Hz
CRANE GROUP.....	FEM A5
HOIST GROUP.....	M6/FEM 3m)
BRIDGE TRAVEL GROUP.....	M5/FEM 2m)
SUPPLY POWER.....	2.75MW
TOLERANCES ACC. TO ISO/FEM STANDARD	
BRIDGE PAINT: EPO/RAL 028	
DRAWING NOT IN SCALE	

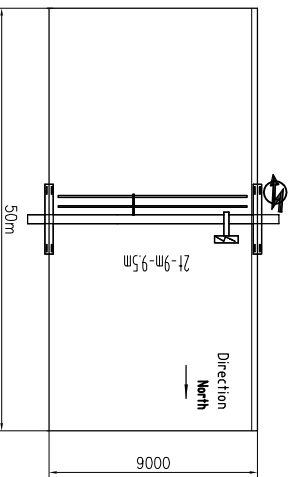
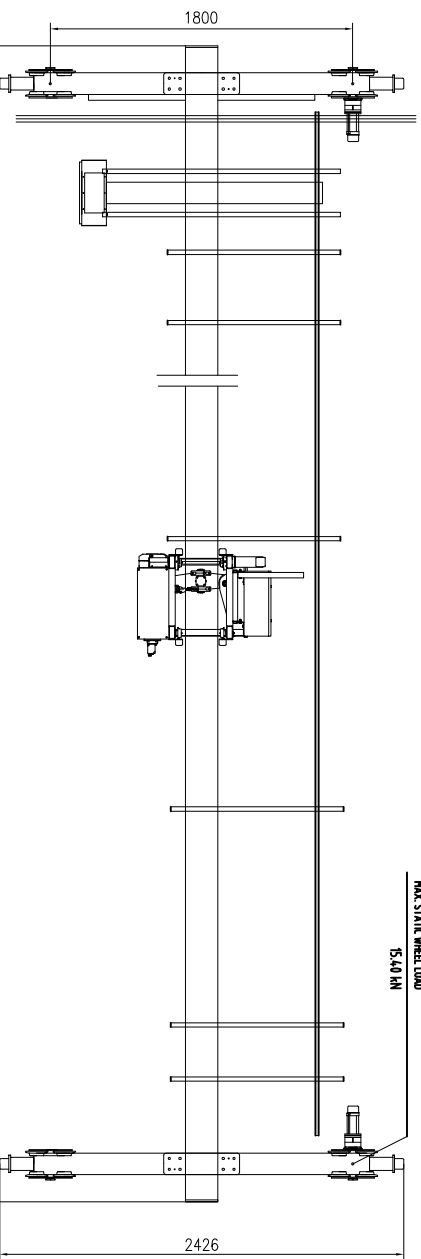

PRELIMINARY DRAWING, OFFER ONLY.

Rev.		Pos.		Area		No./Index		Modified		Name		Material code		Part Name	
Designd	RU02	RU0201		Standard		RU0201									KU17x9m x 9.5m A5
Checked				Approved						Stage	Weight/kg	Issue			
Verified										1500		A.0			
Processed				Scale	1:35	A2	Total	Page	DWG. No.						