

TECHNICAL DATA

LOAD.....	6.3t
SPAN.....	4.2m
LIFTING HEIGHT.....	12m
HOISTING SPEED.....	4/0.7 m/min 2-SPEED
TRAVERSING SPEED.....	0-20 m/min STEPLESS
TRAVELLING SPEED.....	0-20 m/min STEPLESS
WEIGHT OF TROLLEY.....	0.74t
WEIGHT OF CRANE.....	2.2t
POWER SUPPLY.....	380V/48V/50Hz
CRANE GROUP.....	FEM A5
HOIST GROUP.....	M6(FEM 3m)
BRIDGE TRAVEL GROUP.....	M5(FEM 2m)
SUPPLY POWER.....	9.9kW
TOLERANCES ACC. TO ISO/FEM STANDARD	
BRIDGE PAINT: E120/RAL1028	
DRAWING NOT IN SCALE	

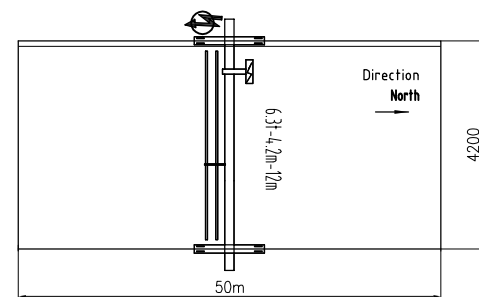
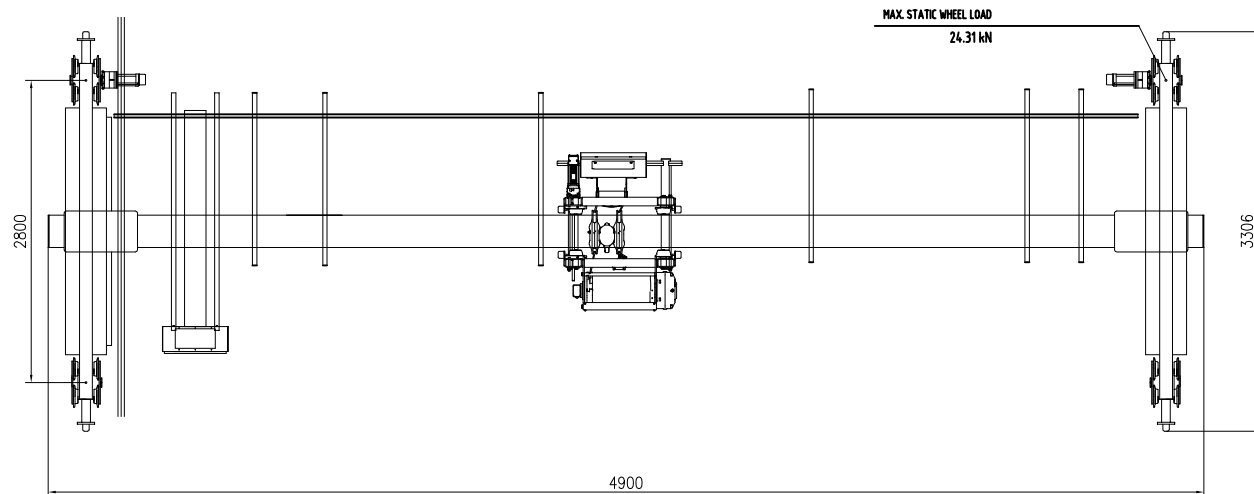

PRELIMINARY DRAWING, OFFER ONLY.

						Material		RU02	
						Material code		Part Name	
Rev.	Pcs.	Area	Mod.Index	Modified	Date	Stage	Weight(Kg)	Issue	KU6.3tX4.2mX12m-A5
Designed	RU02	2024/03/22	Standardized		2024/03/22				
Checked							2200	A0	
Verified		2024/03/22							
Processed			Scale	1:35	A2	Total	Page	DWG No.	