

MAX. STATIC WHEEL LOAD
83.1 kN

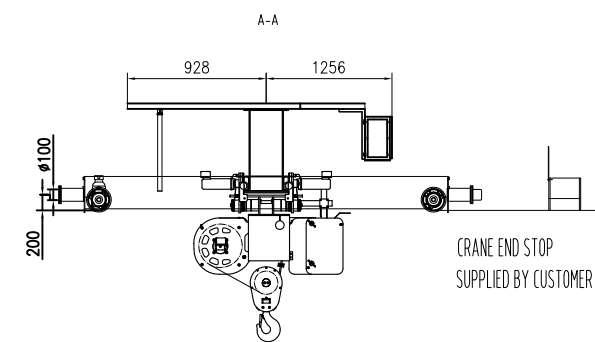

TECHNICAL DATA

LOAD.....	16t
SPAN.....	9m
LIFTING HEIGHT.....	12m
HOISTING SPEED.....	5/0.8 m/min 2-SPEED
TRAVERSING SPEED.....	0-20 m/min STEPLESS
TRAVELLING SPEED.....	0-32 m/min STEPLESS
WEIGHT OF TROLLEY.....	1.6t
WEIGHT OF CRANE.....	4.4t
POWER SUPPLY.....	380V/48V/50Hz
CRANE GROUP.....	FEM A5
HOIST GROUP.....	MS(FEM 2m)
BRIDGE TRAVEL GROUP.....	MS(FEM 2m)
SUPPLY POWER.....	19.8kW
TOLERANCES ACC. TO ISO/FEM STANDARD	
BRIDGE PAINT.....	E120/RAL1028
DRAWING NOT IN SCALE	

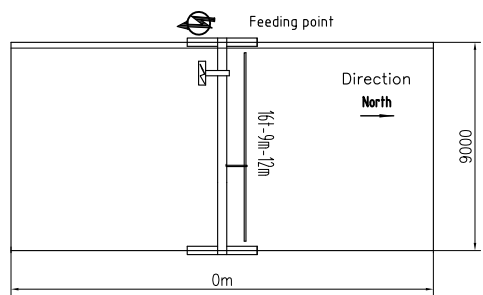

PRELIMINARY DRAWING OFFER ONLY.

						Name			RU02		
						Material code			Part Name		
Rev.	Pcs.	Area	Mod.Index	Modified	Date	Stage			Weight (Kg)		
Designed	RU02	2023/08/22	Standardized						4400		
Checked			Approved		2023/08/22				A0		
Verified		2023/08/22				Size			4400		
Processed			Scale	1:35	A2	Total			Page		
						DWG No.			KS161x9m x 12m-A5		